

MODULAR WALL AND CASING SEALS



In brief...

■ SGM modular wall and casing seals guarantee an absolute air and water tight sealing of the annular space between carrier pipe and casing or between carrier pipe and wall aperture (i.e. wall sleeve).

■ These interlocking modular seals are available in many sizes and have a very wide range of applications.

The SGM system in its range and flexibility constitutes the ideal solution for nearly all applications.

It offers :

- quick and simple installation for all kinds of pipeline.
- positive hydrostatic sealing up to 2 bar.
- electrical insulation between the pipes (cathodic protection).
- absorption of vibrations, shocks and sounds.
- the raw material of the sealing elements complies with standards for conveying drinking water issued by the German Ministry of Health.
- it increases the stability of the carrier pipe.
- generally oil-resistant.



Tel 08-630 10 00, Fax 08-544 402 50
e-post info@karnag.se, www.karnag.se



Characteristics

SGM modular seals developed from a well-known and acclaimed basic system of link sealing, improving it substantially in many ways. The improvements carried out to the material and the construction guarantees you an absolutely reliable seal for wall penetrations in almost any context and in long life durability.

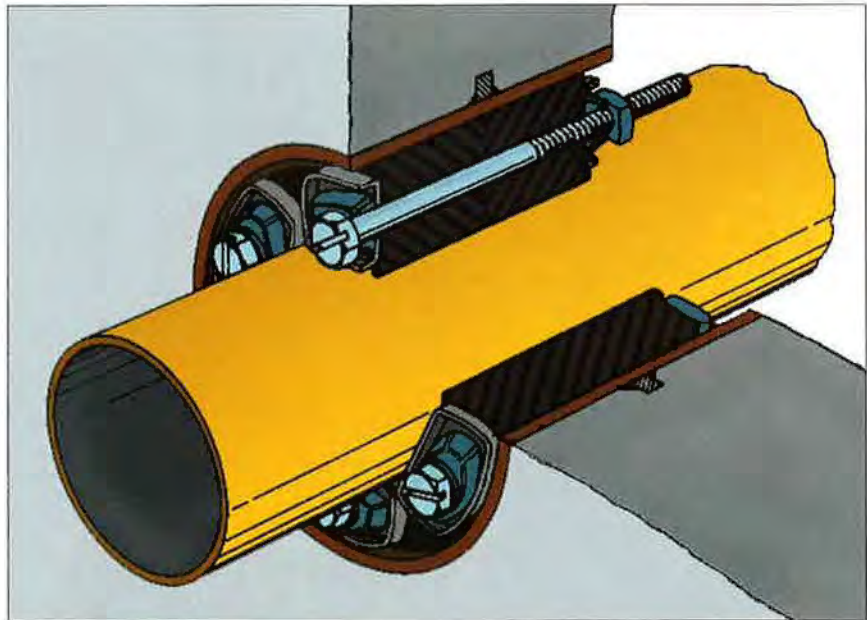

Hydrostatic sealing up to 2 bar :
if the gasket has been correctly fitted to the wall opening to prevent any ejection, pressures up to **6 bar** can be reached.

Temperature resistance :
The SGM modular seals take continuous temperature up to 80°C, and short term peaks up to 110°C.

Shocks and vibrations absorption :
Due to their construction, SGM modular seals are more stable, absorb shocks and vibrations (from changes in internal pipe pressure or ground disturbances) and dampen sounds.

Cathodic protection :
Each metal part is plastic coated and is free from any contact with the pipe.
The raised surrounds on the plastic pressure plates provide a larger spark gap, considerably improving the cathodic protection.



Innovative details make for optimum sealing

Unthreaded bolt head :
no sharp thread edges to slice into the sealing elements during extreme tightening... Thereafter reduced abrasion.

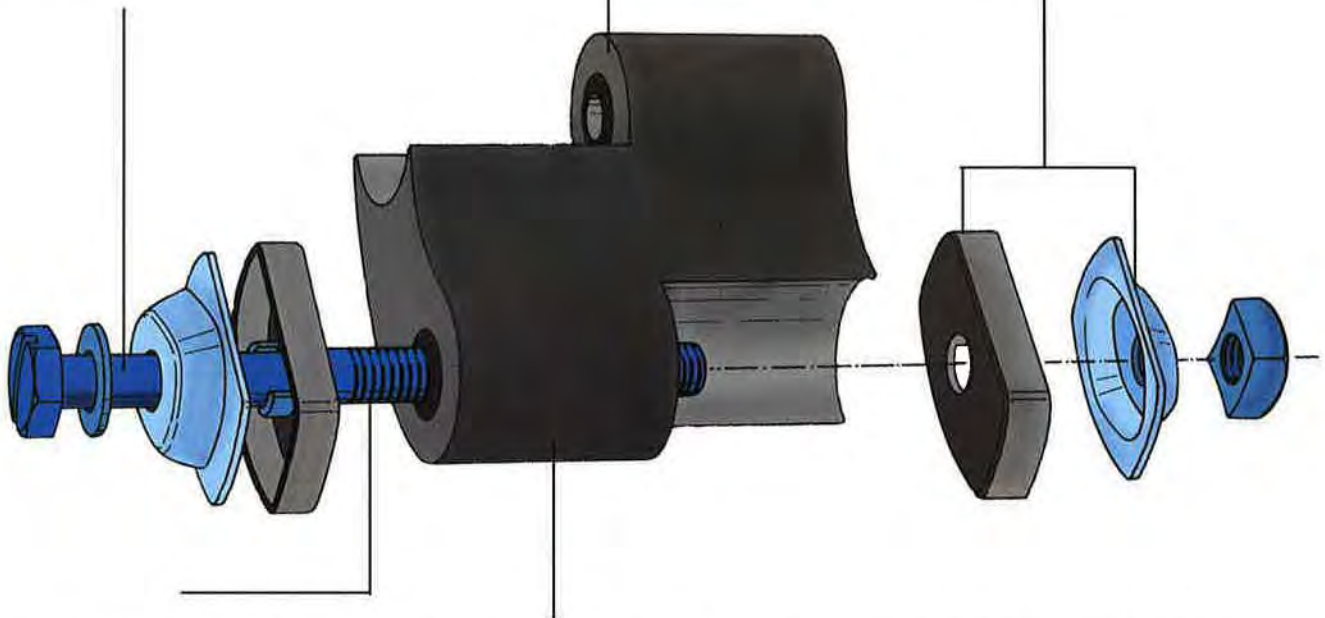

Non toxicity and oil resistance :
the sealing elements are made of thermo-plastic elastomer on nitrile rubber-PVC base.

Plastic pressure plates, steel pressure plates : identically moulded contours :
preventing plastic crackage and allowing stronger tightening.

Thread in stainless steel version is lubricant coated :
prevents reciprocal abrasion, renders the use of water-pollutive greases unnecessary.

Anti-corrosion measures improved :
all metal parts in galvanized yellow zinc plated steel.

Drinking water authorization :
the raw material of the sealing elements is fully in conformance with the specifications relating to drinking water required by the German Ministry of Health.

Improved cathodic protection :
raised surround on plastic pressure plate lengthens spark gap.

Bolts and nuts comply with DIN standards :
no problem about spare parts.

Simple to handle, quick to install

...thanks to their modular structure. SGM modular seals are delivered preassembled to the specified link number – by adding or removing the sealing elements, you can quickly adapt the ring to other pipe diameter.

This is reducing the necessary stock of different sizes to a minimum.



Hexagonal socket head bolts facilitate the assembly of small seal-rings.



Thanks to the special construction of the pressure plates, the nuts can not be distorted.

Options

SGM modular seals are available in 2 versions. For both versions, the raw material of the sealing elements is oil-resistant and conform to the specifications relating to drinking water.

Model SV :

All metal parts are made of galvanized, yellow zinc plated steel.

Model VA :

All metal parts are made of stainless steel V4a. (material nr. 1.4571)

Special material

Available on request : special types made of another raw material (e.g. 1.4539)

Sizes

Twenty-eight different sizes cope flawlessly with all dimensions of annular space.

Model	sealing range in mm	arc length	installation length	Minimum wall thickness	Bolts	spanner size	weight/ piece (kg)
DG 100	9,0 - 12,5	31,4	64	50	M 3 x 60	2,5 Allen key	0,02
DG 200	12,5 - 16	30,5	64	50	M 5 x 60	4 Allen key	0,04
DG 215	12,5 - 16	43,3	64	50	M 5 x 60	4 Allen key	0,05
DG 250	15,5 - 20	28,8	64	50	M 5 x 60	4 Allen key	0,04
DG 265	15,5 - 20	42,4	64	50	M 5 x 60	4 Allen key	0,06
DG 300	17,0 - 23	40,3	90	70	M 6 x 85	5 Allen key	0,10
DG 310	17,0 - 23	57,1	90	70	M 6 x 85	5 Allen key	0,14
DG 315	20,5 - 27	37,7	90	70	M 6 x 85	5 Allen key	0,11
DG 365	20,5 - 27	55,9	90	70	M 6 x 85	5 Allen key	0,15
DG 325	24,5 - 33	77,0	101	70	M 8 x 95	13 HEX.	0,25
DG 350	24,5 - 33	41,9	101	70	M 8 x 95	13 HEX.	0,16
DG 375	31,5 - 40	55,5	101	70	M 8 x 95	13 HEX.	0,23
DG 465	31,5 - 40	93,0	136	100	M 10 x 130	17 HEX.	0,52
DG 400	36,5 - 46	93,0	136	100	M 10 x 130	17 HEX.	0,60
DG 415	36,5 - 46	68,0	136	100	M 10 x 130	17 HEX.	0,46
DG 425	28,5 - 38	93,0	136	100	M 10 x 130	17 HEX.	0,48
DG 450	40,5 - 51	92,0	136	100	M 10 x 130	17 HEX.	0,66
DG 475	40,5 - 51	68,0	136	100	M 10 x 130	17 HEX.	0,52
DG 500	58,5 - 72	99,0	151	110	M 12 x 140	19 HEX.	1,07
DG 565	58,5 - 72	78,5	151	110	M 12 x 140	19 HEX.	0,85
DG 525	48,5 - 60	99,0	151	110	M 12 x 140	19 HEX.	0,96
DG 550	48,5 - 60	78,5	151	110	M 12 x 140	19 HEX.	0,76
DG 600	81,0 - 100	101,0	151	110	M 12 x 140	19 HEX.	1,54
DG 615	81,0 - 100	157,0	151	110	M 12 x 140	19 HEX.	2,30
DG 650	70,5 - 84	104,0	151	110	M 12 x 140	19 HEX.	1,43
DG 665	70,5 - 84	160,1	151	110	M 12 x 140	19 HEX.	2,08
DG 800	128 - 145	167,5	151	110	M 12 x 140	19 HEX.	3,62
DG 865	143 - 165	167,5	151	110	M 12 x 140	19 HEX.	3,94

Important

Models with similar sealing range are available in differing arc lengths. If other considerations do not play a role, use the greater arc length for larger pipe diameters to reduce link numbers and assembly time.

For exact calculations regarding the number and model of links required, use our floppy disc.



If you need information about our sleeves for wall apertures consult our »wall sleeves« leaflet.