

## AIR CONTROL ACCESSORY KIT

### INSTALLATION INSTRUCTIONS

Congratulations on your purchase of a new Firestone Air Control Accessory Kit. This kit was designed to provide inflation control of your Firestone air helper springs. This kit will be an asset to your vehicle, meeting most all of your air supply needs.

Please take a few minutes to read through the instructions, identify the components, and learn how to properly install your Air Control Accessory Kit.

#### NOTE :

The Air Control Accessory kit can be used with all Firestone air helper springs products. If you are installing a Firestone suspension system do not install the air line tubing into the air springs as stated in the suspension system instruction manual. If you are adding the Air Control Accessory kit to an existing Firestone suspension system you will need to deflate the air springs and remove the air line tubing.

### NOTE ON CONNECTING THE AIR LINE TUBING

Cut the air line tubing as squarely as possible. To connect the air line tubing to the fittings push the tubing into the fittings as far as possible. If for any reason the tubing must be removed the collar of the fitting can be pushed toward the body of the fitting and the tubing can be removed. Make sure the air helper springs are deflated. To reassemble make sure the tubing is cut squarely and push back into the fitting.

#### TOOLS REQUIRED :

- 3/16" drill bit
- 1/4" drill bit
- Electrical pliers
- Phillips screw driver
- (2) 7/16" wrenches
- 3/8" drill bit
- Hand drill
- Pliers
- Sharp knife
- Center punch

### PARTS LIST

DUALCONTROLPANEL		1	10-32" X 1" MACHINE SCREW	7
COMPRESSOR	9284	1	10-32" LOCKNUT	7
1/8 NPT STRAIGHT FITTING	3055	1	3/16" WASHER	14
RELAY HARNESS	9307	1	WIRE CONNECTOR	1
30 FT. AIR LINE TUBING		1	RING TERMINAL	2
18 GAGE BLACK WIRE		1	NYLONTIES	15

**FIGURE "A"**

**Air Line & Wiring Diagram**

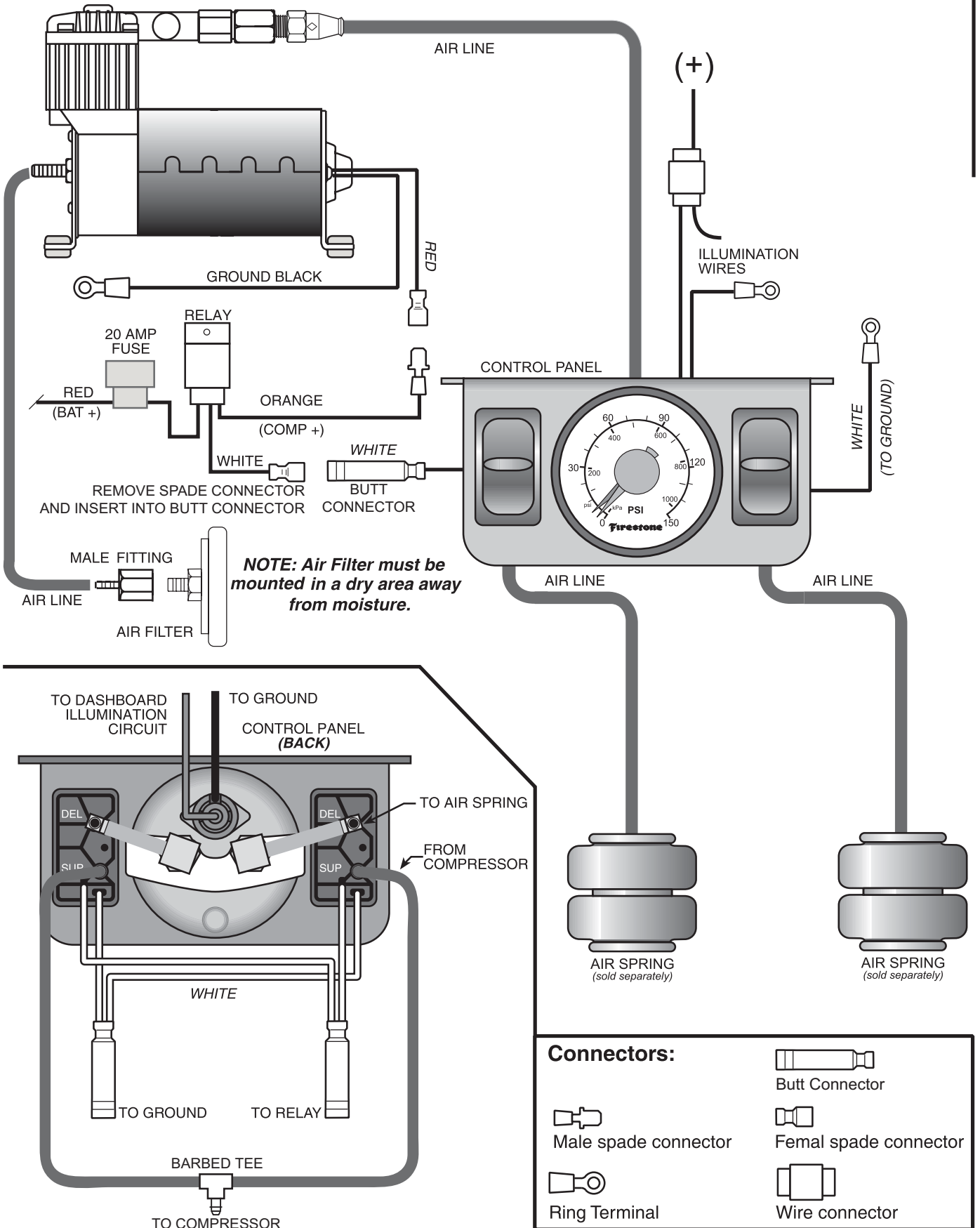

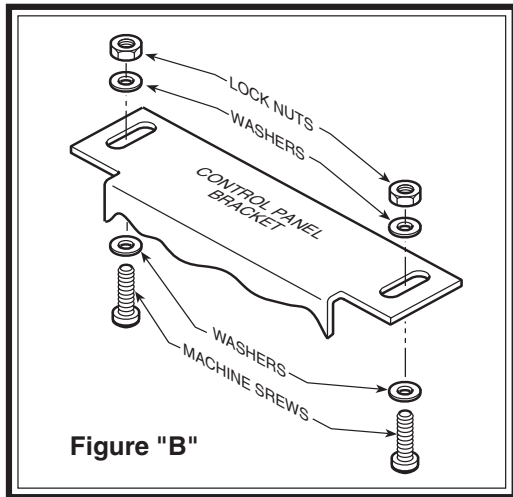

Figure "B"

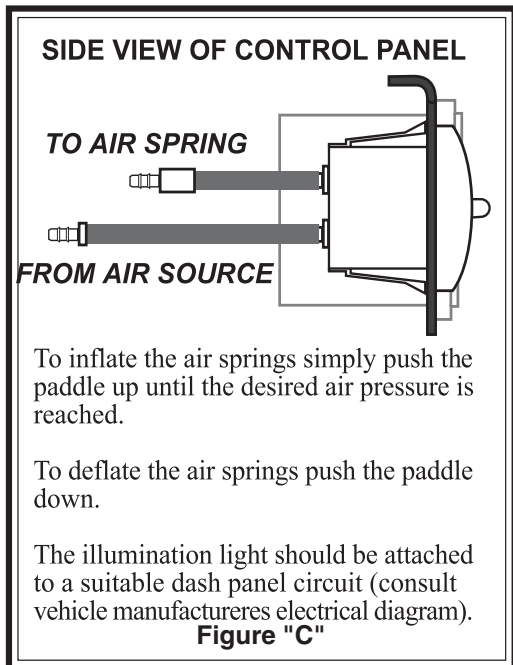

Figure "C"

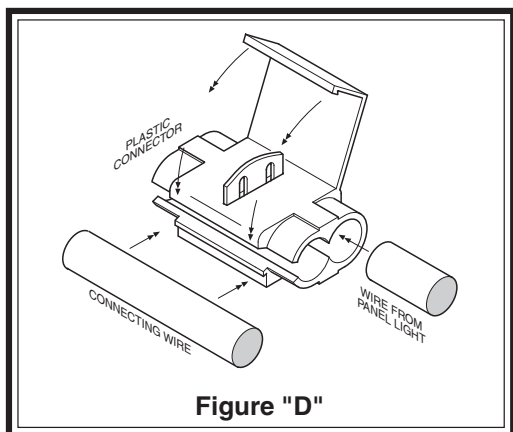

Figure "D"

### STEP 1 LOCATING A MOUNTING AREA FOR THE GAUGE

Select a mounting surface under the dash of your vehicle or other protected location. Mark a 3/16" diameter hole at each of the mounting points, use the air control panel as a template for marking the holes. Drill two 3/16" diameter holes at each of the marked areas, refer to **Figure "B"**. *Do not attach the panel at this time.*

### STEP 2 PREPARING THE COMPRESSOR

Take the compressor from the kit and install the 1/8 NPT straight fitting into the head of the compressor as shown in **Figure "A"**.

### STEP 3 MOUNTING THE COMPRESSOR

Select a convenient location for mounting the air compressor. This location should provide ample air flow and be protected from airborne debris. Mark and drill four 3/16" holes using the compressor as a template for the hole location. Any burrs in the holes should be removed to prevent damage to the rubber isolators. Mount the compressor using the supplied 10-32 x 1" machine screws, 10-32 lock nuts, and 3/16" washers, *see Figure "A"*. Over tightening will crush the brass insert and the rubber isolator, reducing vibration isolation. Before drilling, ensure that there are no electrical, fuel, or brake lines on the opposite side of the mounting surface that can be damaged by the drill. Attach the ring connector on the compressor to a suitable ground source on the vehicle *see Figure "A"*.

### STEP 4 CHECK FOR AIR IN THE SYSTEM

If there is no air pressure in the air springs please proceed with step 6. If there is air pressure in the air springs, both must be deflated. This is done by taking the valve core out of the external inflation valve(s) or use a tire gauge to remove the air from the air springs by depressing the valve stem.

### STEP 5 ROUTING THE AIR LINE TUBING TO THE GAUGE

Cut a piece of air line tubing that will reach from the control panel to the compressor. Make the cut as square as possible. A hole may need to be drilled in the fire wall to enable the air line to pass through the fire wall to the compressor. Remember that 3 pieces of air line will pass through the hole in the fire wall. *Do not fold or kink the air line tubing.* Be sure to avoid direct heat from the engine and exhaust, as well as sharp edges. Insert one end of the air line, as far as possible, into the fitting on the head of the compressor. Before attaching the air line tubing to the control panel soak one end (approximately 1/2") of the air line in warm water for a few minutes. Install the air line onto the barbed tee fitting on the back of the control panel. *See Figure "A" & "C"*. Do not use pliers to work the air line onto the barbed fitting, doing so may damage the tubing or fitting.

### STEP 6 ROUTE AIR LINE TO THE AIR SPRINGS

You will need two lengths of air line tubing, one for each air spring. Cut the two lengths of air line tubing to reach from the control panel to the air springs. Before attaching the air line tubing to the control panel soak one end (approximately 1/2") of the air line in warm water for a few minutes. Install the air line onto the barbed tee fitting on the paddle switch marked "DEL" making sure the air line tubing completely covers the fitting, *see Figures "A" & "C"*. Proceed with the second section of air line on the other switch. (*Hint: The left paddle switch should inflate the left air spring and the right paddle switch should control the right*). Route the air lines from the control panel to the air springs, being careful not to fold or kink the air line tubing. Cut the air line as square as possible and insert the air line tubing into the push-to-connect fitting on the air springs. Use the nylon ties included in the kit to secure the air line to the vehicle. Be sure to avoid direct heat from the engine and exhaust, as well as sharp edges.

**Note:** Avoid sharp edges, exhaust systems and other areas that may cause damage to the air line tubing.

### **STEP 7 ATTACHING THE AIR CONTROL PANEL TO THE DASH**

Place the air control panel on the dash where the holes were drilled in *Step 1*. Using the 10/32 machine screws, nuts, and washers provided in the kit, attach the air control panel to the dash or other appropriate surface, *see Figure "B"*.

There are two wires attached to the gauge on the back of the air control panel for illumination. One will be connected to a suitable fused dash panel circuit for illumination, and the other to a ground source. Consult the vehicle manufacturers electrical diagram. Included in the kit are plastic connectors to assist in wire connection. To use the connectors simply insert the wire into the hole in the plastic connector and slip the connecting wire into the other hole, *see Figure "D"*. Once the wires are in place inside the connector close the top of the plastic connector, the connector will pierce the wire insulation and make a connection with the wire. Pliers can be used to assist in closing the top of the connector. Care should be taken not to crush the connector. *See Figure "D"*. **NOTE:** Should additional wire be necessary, use 18 gage multistrand wire.

### **STEP 8 PREPARING AND ROUTING THE ELECTRICAL WIRE**

Install the relay within three feet of the compressor. Nylon ties can be used to secure any excess wire and the relay neatly into place. Route the white wire labeled "Switch Panel" to the control panel. Cut the spade connector off and strip approximately 1/4" to expose the wire. Insert the exposed white wire into the butt connector on the white wire coming from the switch and crimp. The butt connector can be sealed by applying heat to the coating on the connector. The remaining white wire will be grounded to the vehicle. Using the black wire supplied in the kit, strip approximately 1/4" to expose the wire and crimp on a ring terminal. Next, insert the other exposed end of the black wire into the butt connector on the white wire coming from the switch and crimp. The butt connector can be sealed by applying heat to the coating on the connector. Attach the ring terminal to a suitable ground source. Next, connect the orange wire labeled "Comp +" to the red (positive) wire on the compressor. Connect the red, fused wire labeled "Bat +" from the relay to the battery or another 12V (positive) source capable of supporting 20 amps. *See Figure "A"*.

### **TEST THE SYSTEM**

With the Ride-Rite air accessory kit and Firestone suspension products installed, you are ready to test the system. Turn on the ignition. Push the paddle switch up and the compressor will turn on, supplying air pressure to the air springs. The gauge should read how much air pressure is in the air springs. Each of the air line tubing connections can be inspected with a soap and water solution applied where the fittings and air lines meet. If a leak is detected the air line may not be pushed all the way in or cut squarely.

**NOTE:** The air control accessory kit is designed to monitor the air pressure in the air springs not the pressure between the air compressor and the gauge. If no air is reaching the air springs, or the pressure will not release from the air springs, the air line tubing connections may be reversed. Please review these connections.

### **SYSTEM OPERATION**

When the vehicle is loaded, the rear of the vehicle may drop several inches. The air accessory kit allows the air springs to be inflated from inside the vehicle. Push the paddle up to inflate the air springs and down to deflate the air springs.

**DO NOT EXCEED THE MAXIMUM OPERATING PRESSURE OF THE AIR SPRINGS.**



[www.riderite.com](http://www.riderite.com)